



INDUSTRY 4.0

In picture Hydraulic Unit with Oil Cooler J3 (option).

FP175

STRONG WITH WIDE OPENING

FP175 is the flagship of the FP-series with 830tons force and 12" crimping diameter. It is suitable for wide range of applications requiring large capacity in force and diameter. FP175 with extra long master dies provides long forming with single stroke especially in tube and pipe applications.

ABSOLUTE
QUALITY
MADE IN
FINLAND

TECHNICAL DATA

Max crimping dia (mm/inch) ¹⁾	320/12.60
Max crimping dia with master dies (mm/inch)	330/13
Max. crimping force (kN)	8300
Max. crimping force (tonnage)	830
Cycle time 10 mm (s) ²⁾	3.2
Hydraulic hose size (inch)	10 *
Industrial hose size (inch)	12.60 *
Die set series	32 ³⁾ / 160 ³⁾ / 170
Max. opening (mm) ⁴⁾	+155
Max. opening without dies (mm)	475
Master die D/L (mm)	320/220
Master die D/L (inch)	12.60/8.66
Motor Power (kW/HP)	11/15
Oil tank volume	250 l

DIMENSIONS (LxWxH)

Machine (mm)	1200x936x2220
Hydraulic Unit (mm)	1195x705x1411
Machine (inch)	47.3x36.9x81.9
Hydraulic Unit (inch)	47.0x27.8x44.9

WEIGHT (KG/LBS)

Machine	4455/9801
Hydraulic Unit	305/671

* ACCORDING TO THE FITTING.

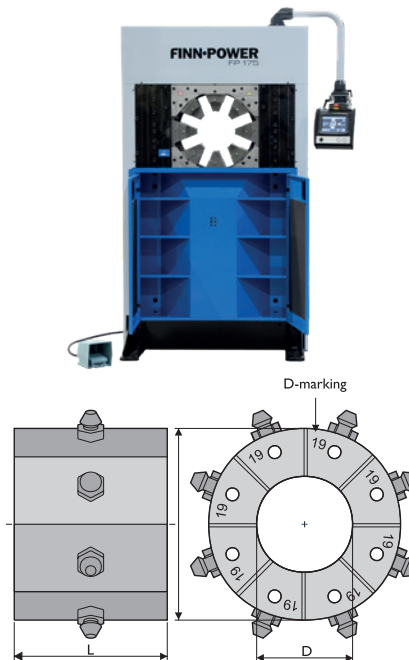

- 1) With standard dies. Crimping range can be increased with special dies.
- 2) Theoretical with 10 mm cycle.
- 3) With adapter dies
- 4) Maximum opening is the total die travel. Add this value to the minimum crimping diameter of the die set used. The result is the maximum opening of the machine with die set in place.

Power supply cable not included.

Please note that the images are for illustrative purposes only. The final product may vary in design, features or specifications.

CONTROL

ICC (7" touchscreen)

STANDARD FEATURES

Adapter dies for FP160-series dies (part no 404916)
Foot pedal (part no 691563)
Pressure crimping ICC1
Step crimping ICC2

OPTIONS

Adapter dies for 32-series dies (part no 302008)
QuickChange-tool 32-series dies (part no 701049)
Smart die rack SDR (16 slot for 32-series dies)
Auto greasing G3
Interface pack ETH (Communication TCP/IP & UDP)
A3 signal
Oil cooler J3**
Pinning support mandrel
Quality control ICC3
Graphical quality control ICC4
Bar Code Reader BCR
Speed adjustment **
Oil Condition Monitoring OCM
Industry 4.0
Camera with 7" display
Horizontal Back layout HB
Horizontal Side layout HS

** Will have impact on motor size, hydraulic unit dimensions and weight

DIE SET 170-SERIES

DieSetNo	D (mm)	L (mm)	Crimp. range (mm)
405060/205	205	220	205.0-220.0
405060/220	220	220	220.0-235.0
405060/235	235	220	235.0-250.0
405060/250	250	220	250.0-270.0
405060/270	270	220	270.0-290.0
405060/290	290	220	290.0-320.0

DIE SET 160-SERIES

DieSetNo	D (mm)	L (mm)	Crimp. range (mm)
18852/84	84	116	84.0-92.0
18852/92	92	116	92.0-100.0
18852/100	100	116	100.0-108.0
18852/108	108	116	108.0-116.0
18852/116	116	116	116.0-126.0
18852/126	126	116	126.0-136.0
18852/136	136	116	136.0-146.0
18852/146	146	116	146.0-156.0
18852/156	156	116	156.0-166.0
18852/166	166	116	166.0-178.0
18852/178	178	116	178.0-190.0
18852/190	190	116	190.0-202.0

DIE SET 32-SERIES

DieSetNo	D (mm)	L (mm)	Crimp. range (mm)
18506/10	10	55	10.0-12.0
18506/12	12	55	12.0-14.0
18506/14	14	55	14.0-16.0
18506/16	16	55	16.0-19.0
18506/19	19	55	19.0-22.0
18506/22	22	70	22.0-26.0
18506/26	26	70	26.0-30.0
18506/30	30	70	30.0-34.0
18506/34	34	75	34.0-39.0
18506/39	39	75	39.0-45.0
18506/45	45	90	45.0-51.0
18506/51	51	90	51.0-57.0
18506/57	57	100	57.0-63.0
18506/63	63	110	63.0-69.0
18506/69	69	110	69.0-75.0
18506/74	74	110	74.0-80.0
18506/78	78	110	78.0-87.0

In addition to the standard die sets, a wide range of special die sets is available on request.